

	Seite
- Die NCX Produkte	42.02
- Stanzeinheiten NCXR	42.03
- Stanzeinheiten NCXS	42.04
- Stanzeinheiten NCXT	42.05
- Zubehör	42.06
- Ersatzteile	42.07
- Stanzeinheiten mit Rolle OCX-OCXR	42.08
- Zwangsrückzug	42.09
- Stanzeinheiten mit Rolle ECX	42.10
- Stanzeinheiten mit Rolle UCX	42.11
- Stanzeinheiten mit Rolle RCX	42.12 - 42.13
- Stanzeinheiten V95 - V96	42.14 - 42.15
- DIVERS	42.16

Standard Stanzeinheit

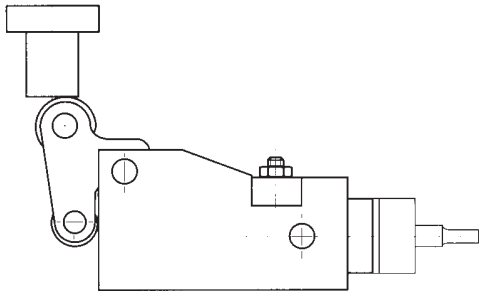

Bestell-Nr.	Max. Hub (mm)	Abstreifkraft (daN)	Ø max. Stempel (mm)	Max. Kraft (daN)
NCXR.3000.020	20	150	10	3000
NCXR.5000.030	30	200	16	5000
NCXR.7000.040	40	250	20	7000
NCXR.10000.050	50	500	25	10000

Stanzeinheit mit Zwangsrückzug

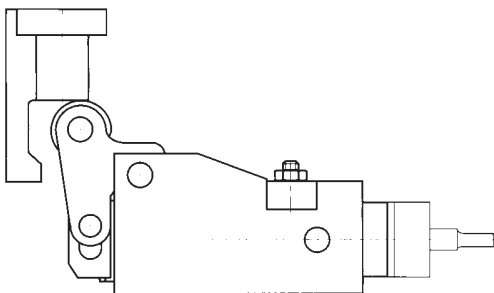

Bestell-Nr.	Max. Hub (mm)	Abstreifkraft (daN)	Ø max. Stempel (mm)	Max. Kraft (daN)
NCXS.3000.020	20	150	10	3000
NCXS.5000.030	30	200	16	5000
NCXS.7000.040	40	250	20	7000
NCXS.10000.050	50	500	25	10000

Stanzeinheit 45° orientiert

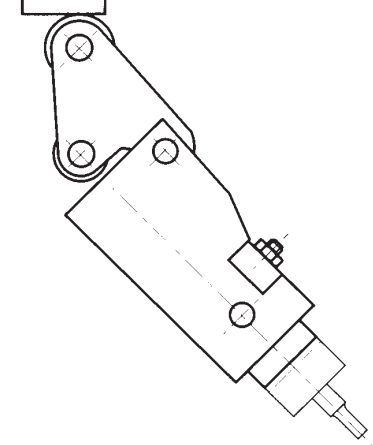

Bestell-Nr.	Max. Hub (mm)	Abstreifkraft (daN)	Ø max. Stempel (mm)	Max. Kraft (daN)
NCXT.3000.020	20	150	10	3000
NCXT.5000.030	30	200	16	5000
NCXT.7000.040	40	250	20	7000
NCXT.10000.050	50	500	25	10000

Bestell-Beispiel :

NCXR.10000.050

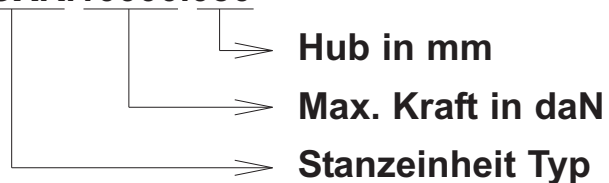

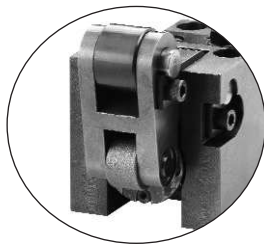

Nach der Positionierung der Stanzeinheit, müssen die Stiftlöcher fertig gebohrt werden.
Das Z-Maß soll 100 mm nicht überschreiten.
Bei einem Z-Maß über 100 mm muß eine zusätzliche Stempelführung berücksichtigt werden.

Bestellbeispiel :
Maximal Kraft : 3000 daN
Mit Druckstück
Bestell-Nr: **NCXR.3000.020**
Nr: **SA.3000**

Stempel-Aufnahmeplatten-Befestigung

Schrauben u. Stiftbohrungen nach Stempel-Aufnahmeplatten abbohren.

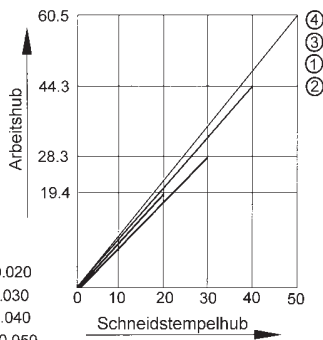
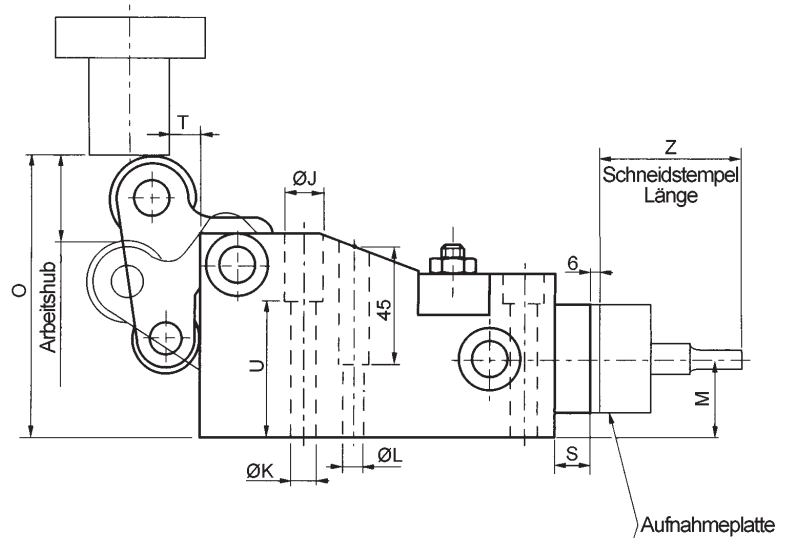
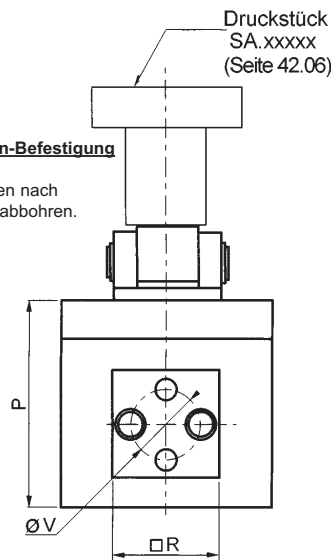

- ① NCXR.3000.020
- ② NCXR.5000.030
- ③ NCXR.7000.040
- ④ NCXR.10000.050

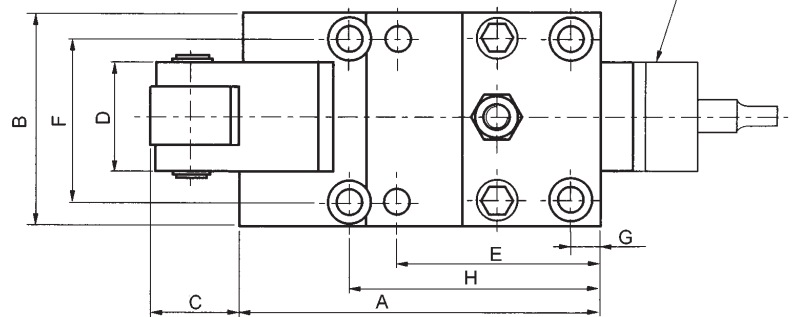

Zwischenmaß für Zylinderstifte Löcher $\pm 0,02$ mm

Bestell-Nr.	Stempel Hub bis	Max. Hub (mm)	A	B	C	D	E	F	G	H	ØJ	ØK	ØL H7	M	O	P	R	S	T	U	ØV	Druckstück
NCXR.3000.020	18	20	123	75	32	36	70	55	10	90	15	9	8	28,5	98	75	45	15	2,5	50	22	SA.3000
NCXR.5000.030	27	30	150	90	36	45	82	67	12	102	18	11	10	35	121	90	45	15	5,6	58	22	SA.5000
NCXR.7000.040	36	40	178	105	45	55	100	80	15	125	20	14	12	42	144	105	56	18	10,8	70	35	SA.7000
NCXR.10000.050	45	50	205	120	57	65	115	92	15	140	20	14	12	48	167	120	63	20	19,9	82	40	SA.10000



Nach der Positionierung der Stanzeinheit, müssen die Stiftlöcher fertig gebohrt werden.
Das Z-Maß soll 100 mm nicht überschreiten.
Bei einem Z-Maß über 100 mm muß eine zusätzliche Stempelführung berücksichtigt werden.

Bestellbeispiel :
Maximal Kraft : 3000 daN
Mit Zwangsrückzug
Bestell-Nr: **NCXS.3000.020**
Nr: **SAS.3000**

Stempel-Aufnahmeplatten-Befestigung

Schrauben u. Stiftbohrungen nach Stempel-Aufnahmeplatten abbohren.

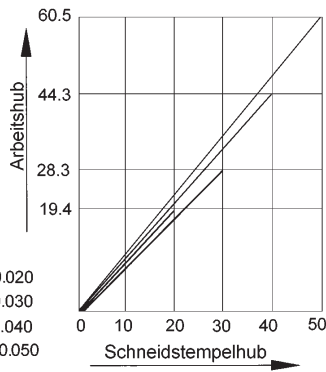
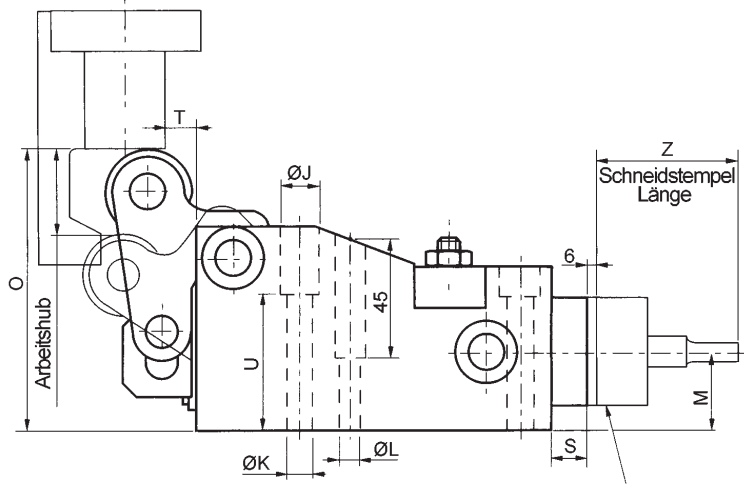
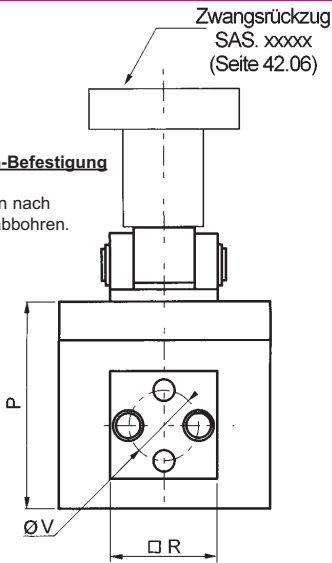

- ① NCXS.3000.020
- ② NCXS.5000.030
- ③ NCXS.7000.040
- ④ NCXS.10000.050

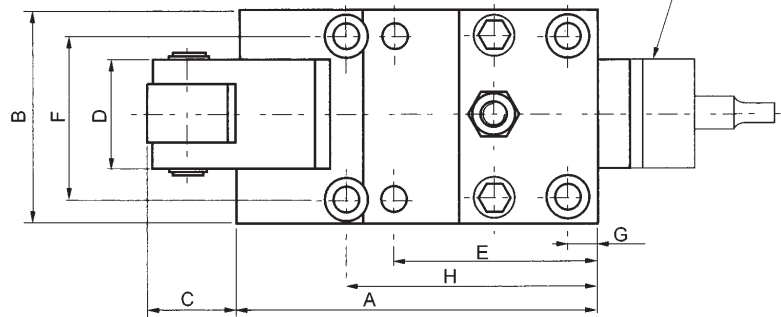

Aufnahmeplatte

Zwischenmaß für Zylinderstifte Löcher $\pm 0,02$ mm

Bestell-Nr.	Stempel Hub bis	Max. Hub (mm)	A	B	C	D	E	F	G	H	ØJ	ØK	ØL H7	M	O	P	R	S	T	U	ØV	Zwangsrückzug
NCXS.3000.020	18	20	123	75	32	36	70	55	10	90	15	9	8	28,5	98	75	45	15	6,5	50	22	SAS.3000
NCXS.5000.030	27	30	150	90	36	45	82	67	12	102	18	11	10	35	121	90	45	15	10,6	58	22	SAS.5000
NCXS.7000.040	36	40	178	105	45	55	100	80	15	125	20	14	12	42	144	105	56	18	19,5	70	35	SAS.7000
NCXS.10000.050	45	50	205	120	57	65	115	92	15	140	20	14	12	48	167	120	63	20	31,5	82	40	SAS.10000



Nach der Positionierung der Stanzeinheit, müssen die Stiftlöcher fertig gebohrt werden.
 Das Z-Maß soll 100 mm nicht überschreiten.
 Bei einem Z-Maß über 100 mm muß eine zusätzliche Stempelführung berücksichtigt werden.

Bestellbeispiel :
 Maximal Kraft : 3000 daN
 Mit Druckstück
 Bestell-Nr: **NCXT.3000.020**
 Nr: **SA.3000**

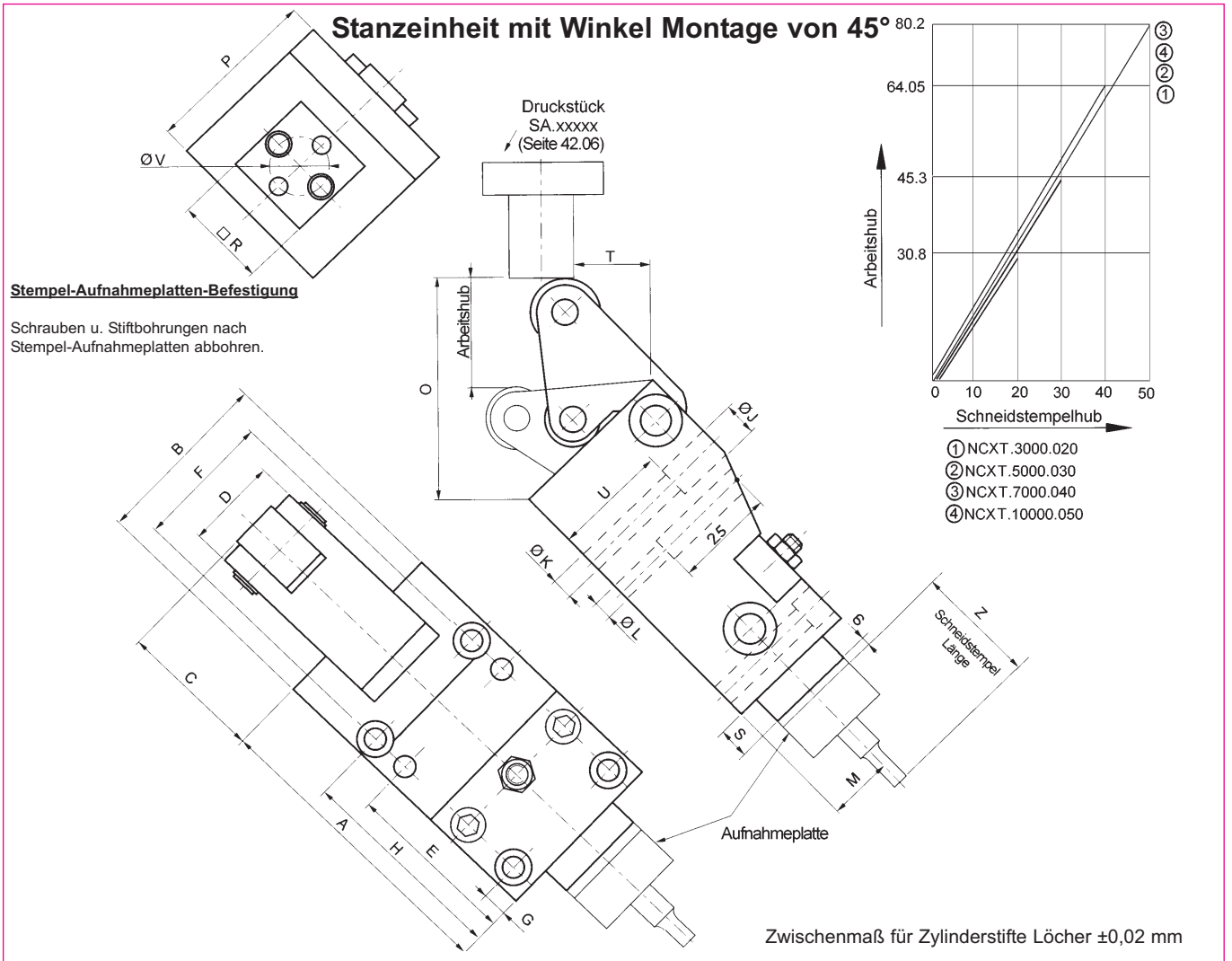

Bestell-Nr.	Stempel Hub bis	Max. Hub (mm)	A	B	C	D	E	F	G	H	ØJ	ØK	ØL H7	M	O	P	R	S	T	U	ØV	Druckstück
NCXT.3000.020	18	20	123	75	67	36	70	55	10	90	15	9	8	28,5	99,85	75	45	15	34,2	50	22	SA.3000
NCXT.5000.030	27	30	150	90	77	45	82	67	12	102	18	11	10	35	116,3	90	45	15	43,6	58	22	SA.5000
NCXT.7000.040	36	40	178	105	87	55	100	80	15	125	20	14	12	42	134,5	105	56	18	51,6	70	35	SA.7000
NCXT.10000.050	45	50	205	120	99	65	115	92	15	140	20	14	12	48	153,8	120	63	20	60,5	82	40	SA.10000

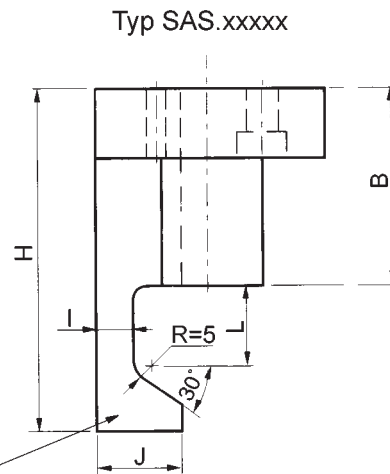
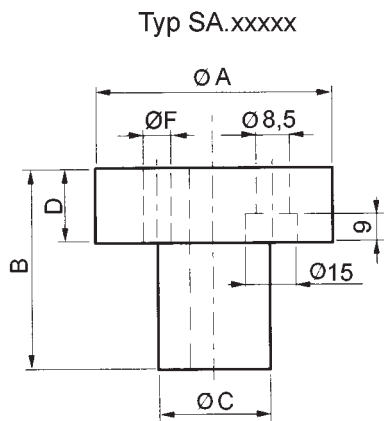

Haken (einzel Teil)
SAS.xxxxx.1

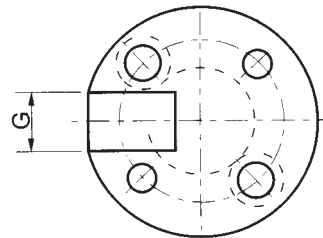
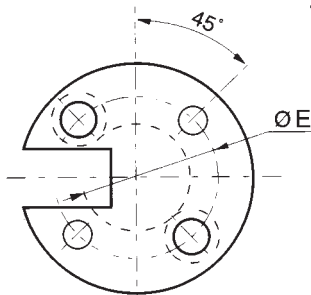

Bestell-Nr.		ØA	B	ØC	D	ØE	ØF	G	H	I	J	L
SA.3000	SAS.3000	70	55	35	20	50	8	20	95	12	25	22
SA.5000	SAS.5000	70	55	35	20	50	8	20	100	12	25	26
SA.7000	SAS.7000	75	70	40	20	55	10	22	125	15	30	30
SA.10000	SAS.10000	75	70	40	20	55	10	22	130	15	30	35

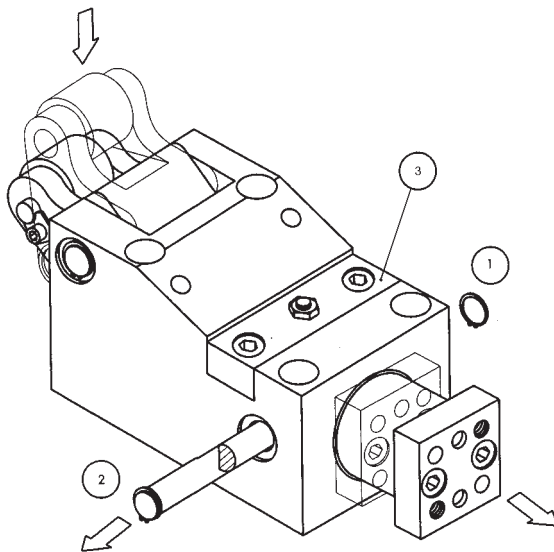

Um die Gasdruckfeder auszubauen sind folgende Schritte zu beachten :

- 1- Einen Federring *er* des Verriegelungsbolzen lösen
- 2- Verriegelungsbolzen & austreiben.
- 3- Keil *•* abmontieren und Schiebermechanismus in Pfeil Richtung entnehmen.
- 4- Nach dem Abmontieren der Abrollplatte (Teil Nr 9) kann die Gasdruckfeder (Teil Nr 1) entfernt werden

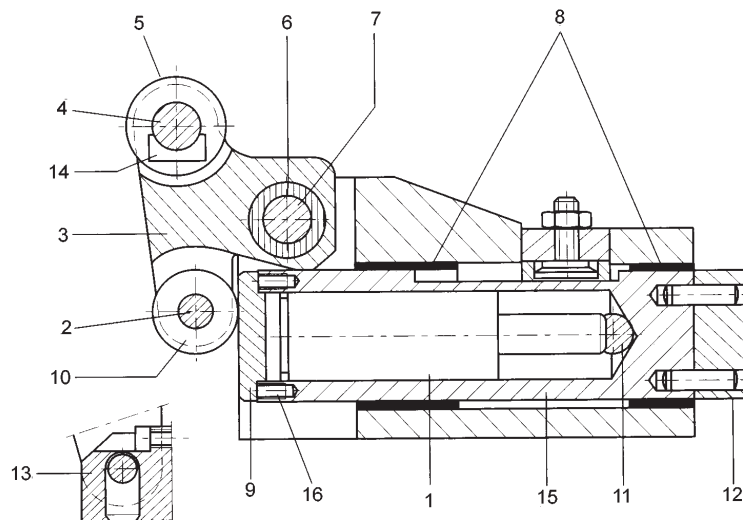

Pos.	Teil	Ersatzteil-Nr.			
		3000	5000	7000	10000
1	Gasdruckfeder	NCX.3000.01	NCX.5000.01	NCX.7000.01	NCX.10000.01
2	Unterachse	NCX.3000.02	NCX.5000.02	NCX.7000.02	NCX.10000.02
3A	Nocken für NCXR und NCXS	NCX.3000.03	NCX.5000.03	NCX.7000.03	NCX.10000.03
3B	Nocken für NCXT	NXCT.3000.03	NCXT.5000.03	NCXT.7000.03	NCXT.10000.03
4	Oberachse	NCX.3000.04	NCX.5000.04	NCX.7000.04	NCX.10000.04
5	Oberrolle	NCX.3000.05	NCX.5000.05	NCX.7000.05	NCX.10000.05
6	Lagerbuchse	NCX.3000.06	NCX.5000.06	NCX.7000.06	NCX.10000.06
7	Lagerbolzen	NCX.3000.07	NCX.5000.07	NCX.7000.07	NCX.10000.07
8	Schieberbuchsen	NCX.3000.08	NCX.5000.08	NCX.7000.08	NCX.10000.08
9	Abrollplatte	NCX.3000.09	NCX.5000.09	NCX.7000.09	NCX.10000.09
10	Unterrolle	NCX.3000.10	NCX.5000.10	NCX.7000.10	NCX.10000.10
11	Verriegelungsbolzen	NCX.3000.11	NCX.5000.11	NCX.7000.11	NCX.10000.11
12	Stempel-Aufnahmeplatte	NCX.3000.12	NCX.5000.12	NCX.7000.12	NCX.10000.12
13	Abrollplatte für NCXS	NCX.3000.13	NCX.5000.13	NCX.7000.13	NCX.10000.13
14	Sicherungsplatte	NCX.3000.14	NCX.5000.14	NCX.7000.14	NCX.10000.14
15	Schiebermechanismus	NCX.3000.15	NCX.5000.15	NCX.7000.15	NCX.10000.15
16	Befestigungsschraube	NCX.3000.16	NCX.5000.16	NCX.7000.16	NCX.10000.16



Bei den Stanzeinheiten OCX und OCXR sind die unterschiedlichen Befestigungsbohrungen zu beachten.

Bestellbeispiel :

Maximal Kraft : 3000 daN
Maximal Hub : 50 mm
Bestell-Nr: **OCX.3000.050**

Rechtsicht Typ OCX

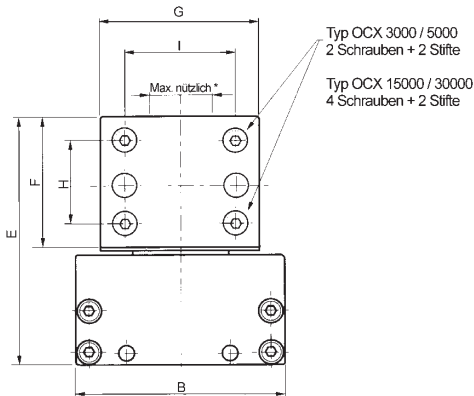

Stempel-Aufnahmeplatten-Befestigung

Schrauben u. Stiftbohrungen nach Stempel-Aufnahmeplatten abbohren

* 30 mm max. für OCX/R 3000/5000
65 mm max. für OCX/R 15000/20000

Vordersicht Typ OCXR

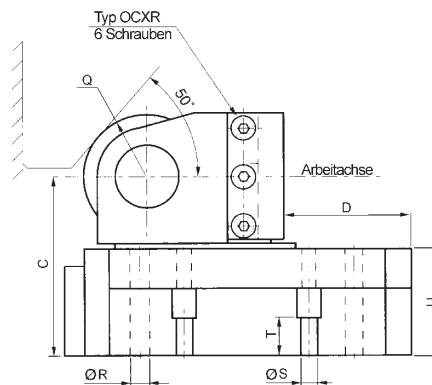

Draufsicht Typ OCX / OCXR

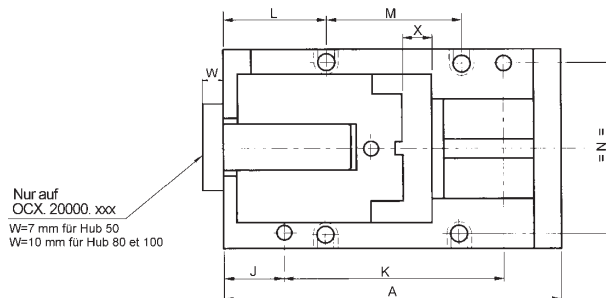

Zwischenmaß für Zylinderstifte Löcher ±0,02 mm

Bestell-Nr.	Max. Kraft (daN)	Abstreifkraft (daN)	Hub (mm)	Stempel Hub bis (mm)	A	B	C	D	E	F	G	H	I	J	K	L	M	N	Q	ØR H7	ØS	T	U	X		
OCX.3000.050	3000	150	50	50	190		86	117	63		43				134	76										
OCXR.3000.050			80	72	220	100	86	74	117	63	63	43	43	30	164	59	106	80	31	8	8,5	15	48	15		
OCX.3000.080			100	90	260		110		141	87		67			204		146									
OCXR.3000.100																										
OCX.5000.050			5000	150	50	50	190		103	140	74		54				134	76								
OCXR.5000.050	80	72			220	130	103	74	140	74	90	54	70	30	164	59	106	110	36	8	8,5	18	60	15		
OCX.5000.080	100	90			260		120		157	91		71			204		146									
OCXR.5000.080																										
OCX.5000.100																										
OCXR.5000.100																										
OCX.15000.050	15000	250	50	50	190			43							131	67										
OCXR.15000.050			80	72	220	170	120	73	165	90	135	65	102,5	32	161	64	97	148	45	10	10,5	14	67	25		
OCX.15000.080			100	90	260			73							201		137									
OCXR.15000.080																										
OCX.15000.100																										
OCXR.15000.100																										
OCX.20000.050	20000	500	50	50	220			48							152	80										
OCXR.20000.050			80	72	250	240	135	78	190	110	200	85	167,5	34	182	70	110	218	55	12	13	17	72	25		
OCX.20000.080			100	90	270			78							202		130									
OCXR.20000.080																										
OCX.20000.100																										
OCXR.20000.100																										

MAXIMALE SCHRÄGSTELLUNG

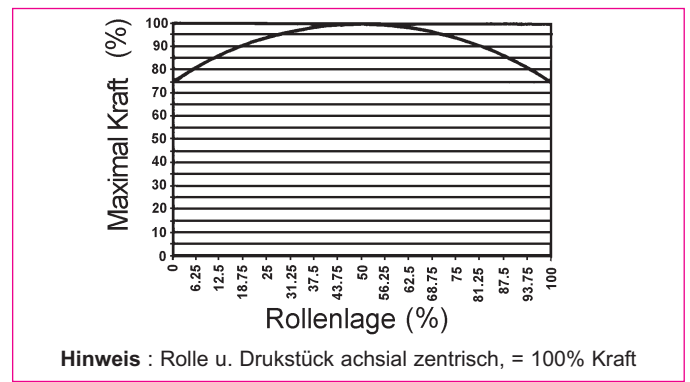
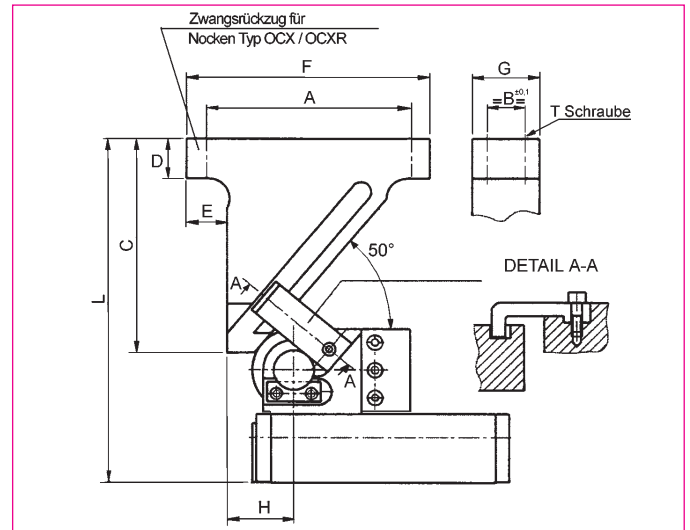
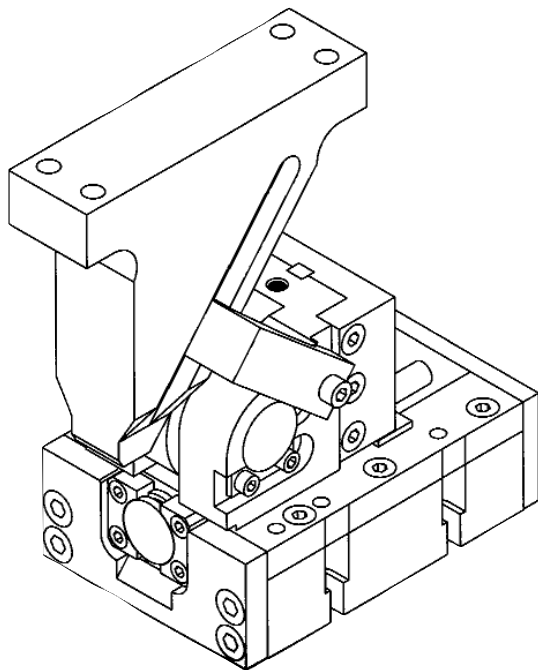
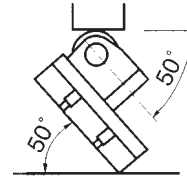
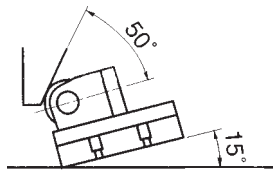

Bestell-Nr	A	B	C	D	E	F	G	L	T	H
SAT.3000.050	150	28	162	30	30	180	50	261	M10	49,6
SAT.3000.080	180	28	199	30	30	210	50	298	M10	49,6
SAT.3000.100	200	28	220	30	30	230	50	343	M10	49,6
SAT.5000.050	150	28	162	30	30	180	50	278	M10	57,4
SAT.5000.080	180	28	199	30	30	210	50	315	M10	57,4
SAT.5000.100	200	28	220	30	30	230	50	353	M10	57,4
SAT.15000.050	192	30	190	40	40	222	60	323	M12	72,8
SAT.15000.080	222	30	226	40	40	252	60	359	M12	72,8
SAT.15000.100	244	30	250	40	40	274	60	383	M12	72,8
SAT.20000.050	192	30	190	40	40	222	60	340	M12	84,2
SAT.20000.080	222	30	226	40	40	252	60	376	M12	84,2
SAT.20000.100	244	30	190	40	40	274	60	400	M12	84,2

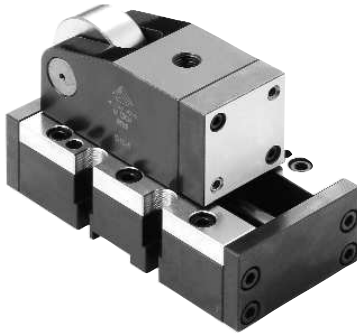

Bestellbeispiel :
 Maximal Kraft : 3000 daN
 Maximal Hub : 50 mm
 Bestell-Nr : **ECX.3000.050**

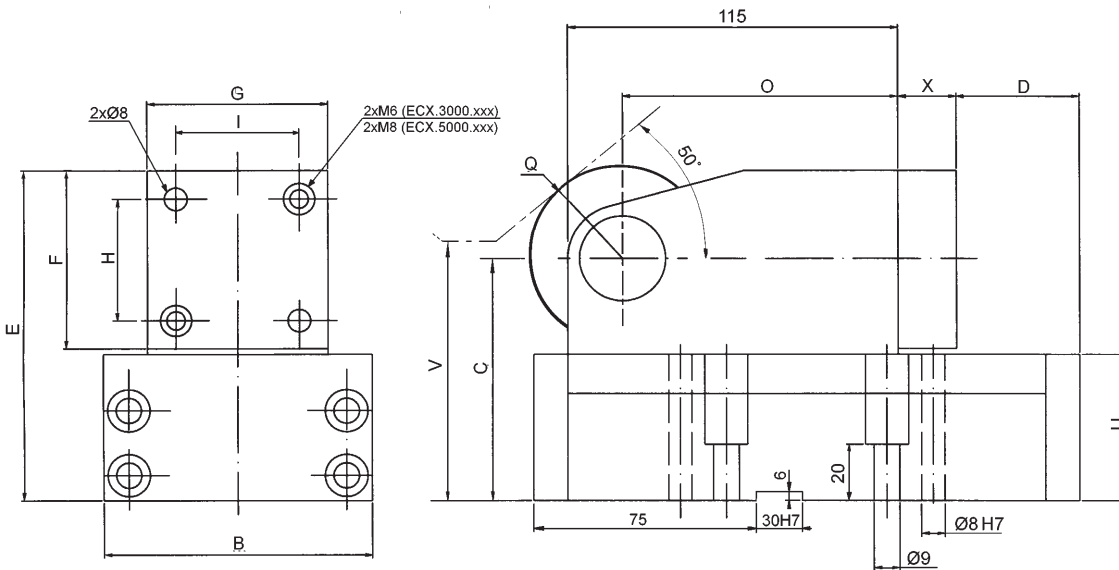

Stempel-Aufnahmeplatten-Befestigung

Schrauben u. Stiftbohrungen nach Stempel-Aufnahmeplatten abbohren.

MAXIMALE SCHRÄGSTELLUNG

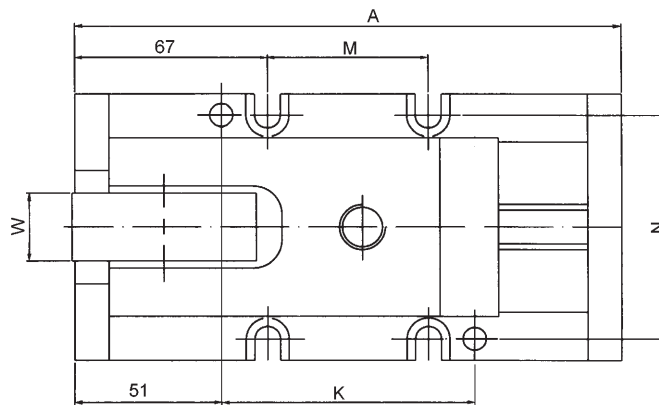
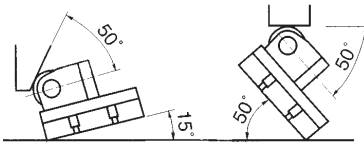

Zwischenmaß für Zylinderstifte Löcher ±0,02 mm

Bestell-Nr.	Maximal Kraft (daN)	Abstr. Kraft (daN)	Hub (mm)	Stempel Hub bis (mm)	A	B	C	D	E	F	G	H	I	K	M	N	O	Q	U	V	W	X
ECX.3000.050	3000	200	50	45	190	94	86	43	117	63	63	43	43	88	56	79	96	31	52	60	24	20
ECX.3000.080			80	72	220			73						118	86					96		
ECX.5000.050	5000	200	50	45	190	120	103	43	140	74	90	54	70	88	56	105	91	36	62	60	28	20
ECX.5000.080			80	72	220			73						118	86					96		
ECX.5000.100			100	90	260			120						103	157					158		

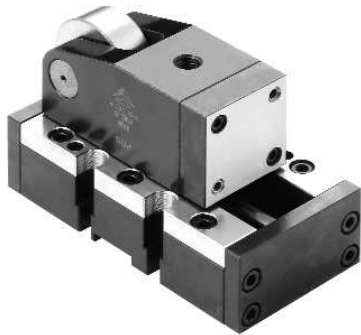

Bestellbeispiel :
 Maximal Kraft : 5000 daN
 Maximal Hub : 50 mm
 Bestell-Nr : **UCX.5000.050**

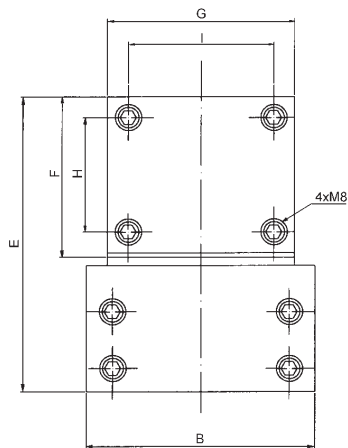

Stempel-Aufnahmeplatten-Befestigung

Schrauben u. Stiftbohrungen nach Stempel-Aufnahmeplatten abbohren.

MAXIMALE SCHRÄGSTELLUNG

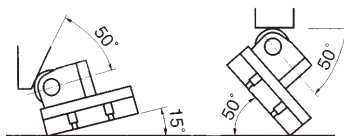

Zwischenmaß für Zylinderstifte Löcher $\pm 0,02$ mm

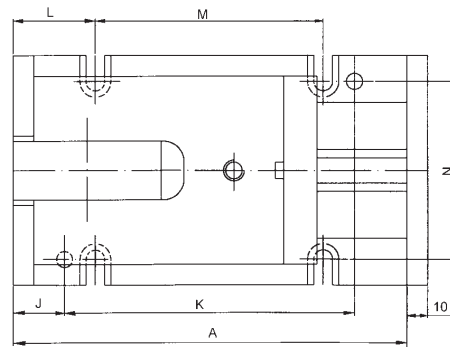
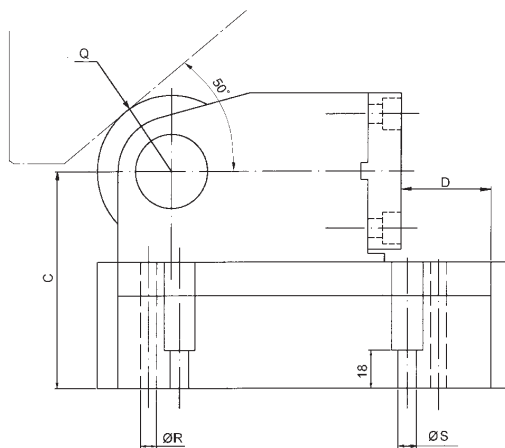

Bestell-Nr.	Maximal Kraft (daN)	Abstr. Kraft (daN)	Hub (mm)	Stempel Hub bis (mm)	A	B	C	D	E	F	G	H	I	J	K	L	M	N	Q	ØR H7	ØS
UCX.5000.050	5000	150	50	50	190		103	43	140						140	110					
UCX.5000.080			80	72	220	110	103	73	140	74	90	54	70	25	170	40	140	85	36	8	9
UCX.5000.100			100	90	260			120	102	157						210	180				
UCX.15000.050	15000	150	50	50	190		115	43	160						140	110					
UCX.15000.080			80	72	220	155	115	73	160	90	135	70	115	25	170	40	140	126	45	10	11
UCX.15000.100			100	90	260			132	93	177						210	180				
UCX.20000.050	20000	250	50	50	215			43							161	115					
UCX.20000.080			80	72	245	210	127	73	182	110	200	86	176	27	191	50	145	176	55	12	14
UCX.20000.100			100	90	265			93								211	165				



Bestellbeispiel :
 Maximal Kraft : 3000 daN
 Maximal Hub : 50 mm
 Bestell-Nr : **RCX.3000.050**

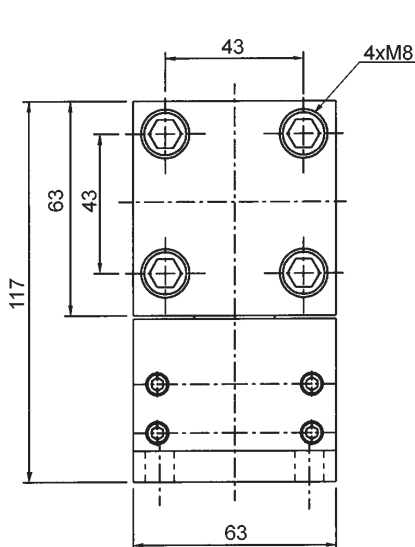

Stempel-Aufnahmeplatten-Befestigung

Schrauben u. Stiftbohrungen nach Stempel-Aufnahmeplatten abbohren.

MAXIMALE SCHRÄGSTELLUNG

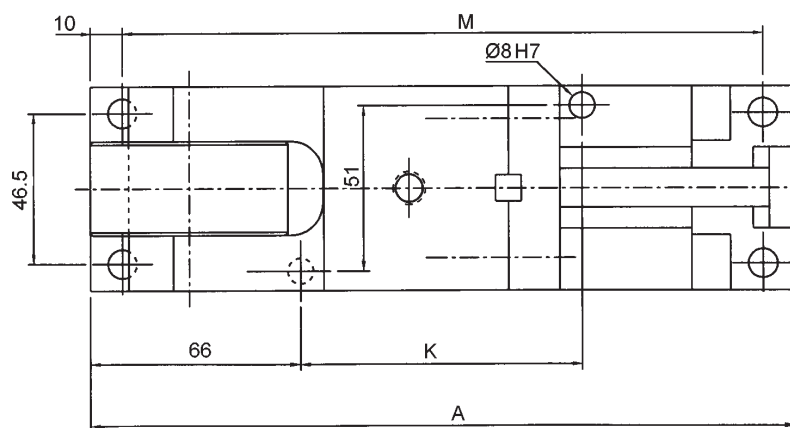
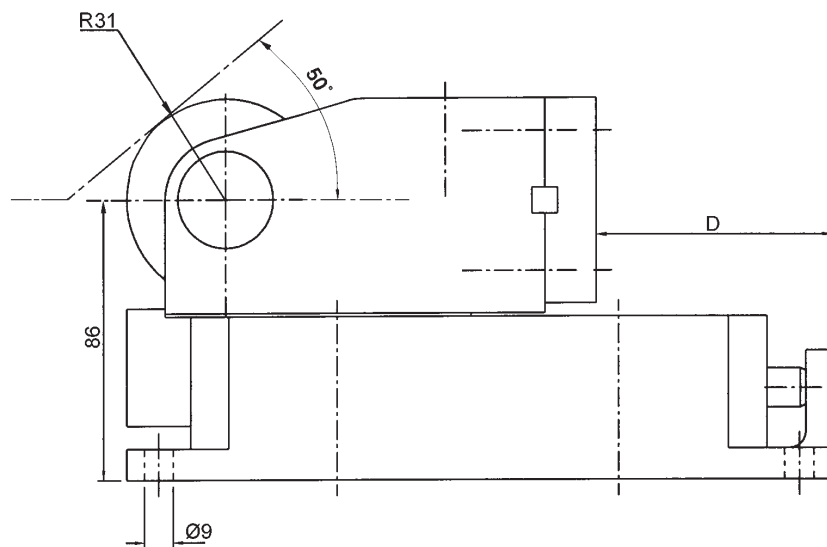
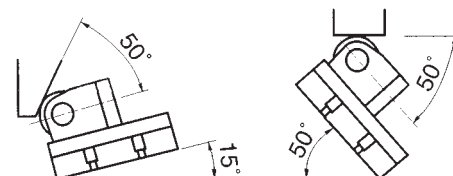

Zwischenmaß für Zylinderstifte Löcher $\pm 0,02$ mm

Bestell-Nr.	Maximal Kraft (daN)	Abstreifkraft (daN)	Hub (mm)	Stempel-Hub bis (mm)	A	D	K	M
RCX.3000.050	3000	100	50	45	190	43	58	170
RCX.3000.080			80	72	220	73	88	200



Bestellbeispiel :
 Maximal Kraft : 5000 daN
 Maximal Hub : 50 mm
 Bestell-Nr : RCX.5000.050



Stempel-Aufnahmeplatten-Befestigung

Schrauben u. Stiftbohrungen nach Stempel-Aufnahmeplatten abbohren.

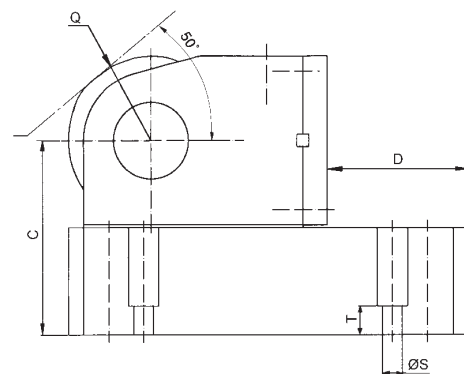
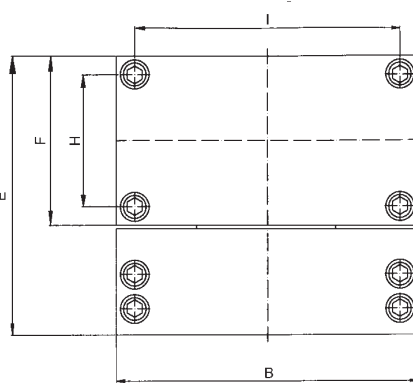

MAXIMALE SCHRÄGSTELLUNG

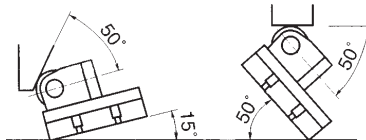

Zwischenmaß für Zylinderstifte Löcher ±0,02 mm

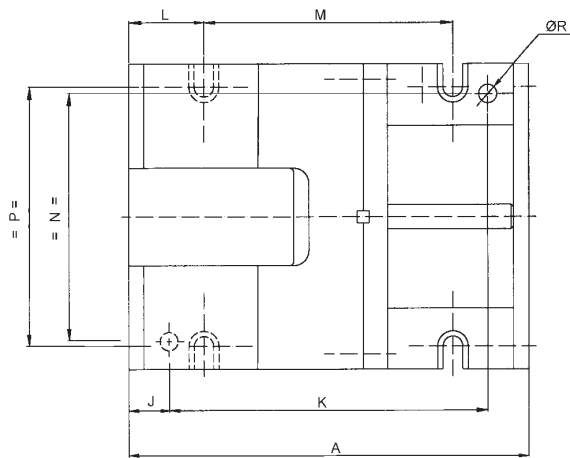

Bestell-Nr.	Maximal Kraft (daN)	Abst. Kraft (daN)	Hub (mm)	Stempel-Hub bis (mm)	A	B	C	D	E	F	H	I	J	K	L	M	N	P	Q	ØR H7	ØS	T
RCX.5000.050	5000	100	50	45	190		103	43	140					140	110							
RCX.5000.080			80	72	220	90	103	73	140	74	54	70	25	170	40	140	70	36	8	9	20	
RCX.5000.100			100	90	260		120	102	157						210	180						
RCX.15000.050	15000	150	50	45	190		115	43	160					140	110							
RCX.15000.080			80	72	220	135	115	73	160	90	70	115	25	170	40	140	115	119	45	10	11	20
RCX.15000.100			100	90	260		132	93	177						210	180						
RCX.20000.050	20000	250	50	45	215			43						161	115							
RCX.20000.080			80	72	245	200	127	73	182	110	86	176	27	191	50	145	170	55	12	13	19	
RCX.20000.100			100	90	265			93							211	165						

Bestellbeispiel :
Kraft : 15 T
Schneidstempel mit federndem Abdruckstift rechteckig mit Verdrehesicherung.
P=10 mm ; W=20,5 mm
Material : 12% Cr

Bestell-Nr :

V95.151.25 1 AE P=10 W=20,5 rechteckig

Form	Drehen *	Material und Abdruckstift	
Standard rund ØMax P1 oder P2	0 oder 1	A	Schneidstempel HWS
Quadratisch P	1	M	Schneidstempel HSS
90° Rechteckig 0° P W		AE	Schneidstempel HWS Abdruckstift
90° Länglich 0° P W		ME	Schneidstempel HSS mit Abdruckstift

*0 : Ohne Verdrehesicherung

1 : Mit Verdrehesicherung

 - Wenn $P < W$ ist, wird der Stempel hochkant (90°) positioniert.

 - Die Diagonal $\sqrt{P^2 + W^2} < P1$ oder $P2$

Bestell-Nr.		Max. Kraft (T) Ⓢ	Max. Dicke des Material mm	Abstreifkraft daN		max. Durchmesser		J		V
Innen Feder	Außen Feder			Innen	Außen	P1 Innen	P2 Außen	Inn.	Auß.	
V95.011.06	V96.011.06	1,5	1,5	170	60	4,7	6	20,62	17	
V95.031.10	V96.031.10	3		200	140	7,9	10	28,57	21	
V95.051.13	V96.051.13	5		210	140	11,1	13	30,15	22	
V95.081.16	V96.081.16	8		260	240	14,3	16	38,10	25	
V95.012.06	V96.012.06	1,5	1,5	170	60	4,7	6	20,62	17	
V95.032.10	V96.032.10	3		200	140	7,9	10	28,57	21	
V95.052.13	V96.052.13	5		210	140	11,1	13	30,15	22	
V95.082.16	V96.082.16	8		260	240	14,3	16	38,10	25	
V95.151.20	V96.151.20	15	3	310	380	17,4	20	46,02	46,02	29
V95.151.22	V96.151.22			320		20,6	22,2		44,45	35
V95.151.25	V96.151.25			460		23,8	25		42,85	41
V95.152.20	V96.152.20	15	3	310		17,4	20		46,02	29
V95.152.22	V96.152.22			320		20,6	22,2		44,45	35
V95.152.25	V96.152.25			460		23,8	25		42,85	41
V95.251.31	V96.251.31	25	6	480	750	28,6	31,7	66,67	48	
V95.251.34	V96.251.34			490		31,7	34,9		54	
V95.251.38	V96.251.38			510		34,9	38,1		60	
V95.252.31	V96.252.31	25	6	480		28,6	31,7		48	
V95.252.34	V96.252.34			490		31,7	34,9		54	
V95.252.38	V96.252.38			510		34,9	38,1		60	

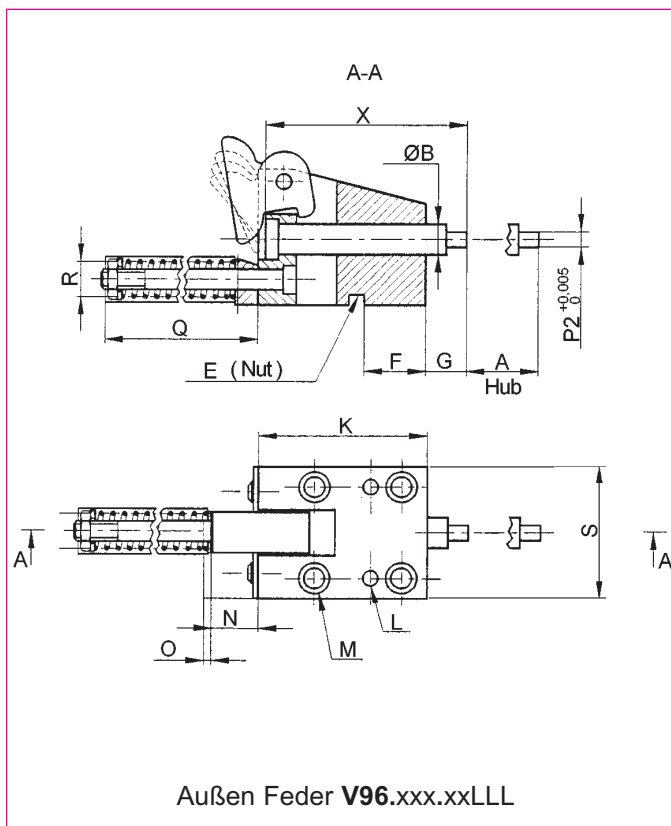
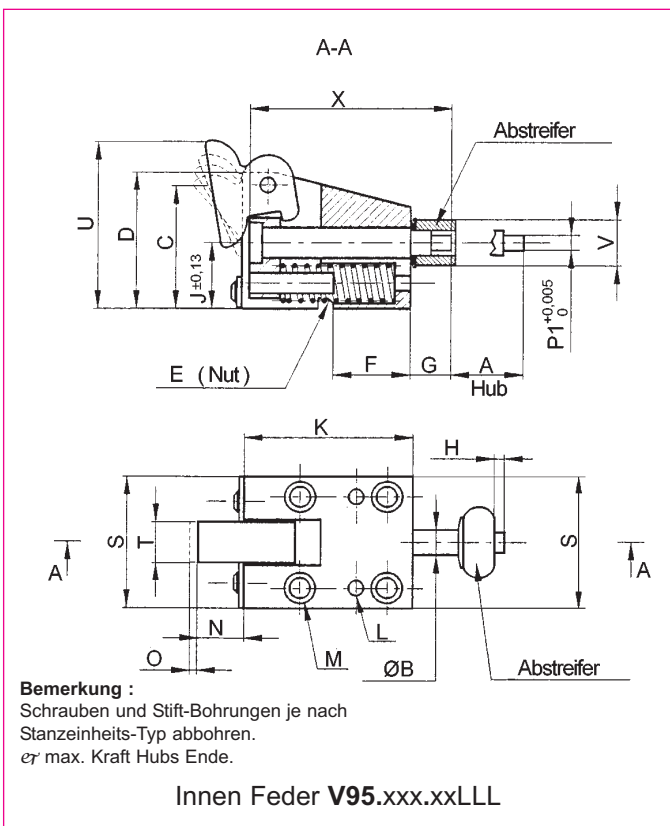

Bestell-Nr.		A	B	C	D	E	F	G	H	K	L		M		N	O	Q	R	S	T	U	X		
Innen Feder	Außen Feder										Nb	Ø	Nb	Ø										
V95.011.06	V96.011.06	9,5	6	43	44	4,8x2,4	12,7	22	6	44	6		M6	13	5	73	16	44	16	54	63			
V95.031.10	V96.031.10	12,7	10	56	57	6,4x3,2	17,5			57			8	2	M8	16	6	111	19	57	19	68	76	
V95.051.13	V96.051.13	16	13	57	63	8x4	20,6			63	10					M10	24	5	124	25	76	25	86	95
V95.081.16	V96.081.16	19	16	64	76	9,6x4,8	25,4			76			6	2	M6		13	5	105	16	44	16	54	89
V95.012.06	V96.012.06	19	6	34	44	4,8x2,4	25,4			70	8	4				M8	16	6	137	19	57	19	68	102
V95.032.10	V96.032.10	22	10	46	57	6,4x3,2	30,2			83			8		M10		16	6	149	63	22	73	108	
V95.052.13	V96.052.13	25	13	48	63	8x4	31,7			89	10					M10	24	5	162	25	76	25	86	121
V95.082.16	V96.082.16	28	16	56	76	9,6x4,8	47,6			102														
V95.151.20	V96.151.20	32	20	80	95	12,7x6,4	47,6			29	9	114	16	M14	31	10	32	89	29	114				
V95.151.22	V96.151.22		222													162								
V95.151.25	V96.151.25		25																					
V95.152.20	V96.152.20	50	20	65	95	12,7x6,4	47,6	29	9	165	6		238											
V95.152.22	V96.152.22		222																				190	
V95.152.25	V96.152.25		25																					
V95.251.31	V96.251.31	38	31,7	132	140	12,7x6,4		41	9	152	4		190											
V95.251.34	V96.251.34		34,9																				190	190
V95.251.38	V96.251.38		38,1																					
V95.252.31	V96.252.31	63	31,7	110	140	12,7x6,4		41	9	216	6	M14	49	10	38	102	41	170						
V95.252.34	V96.252.34		34,9											292	254									
V95.252.38	V96.252.38		38,1																					

BEISPIELE

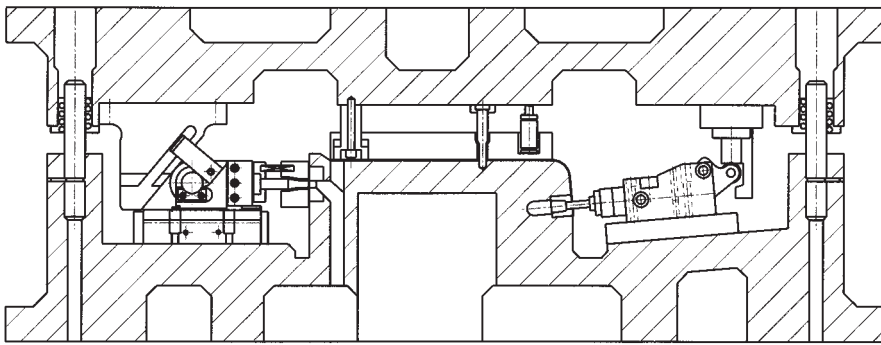
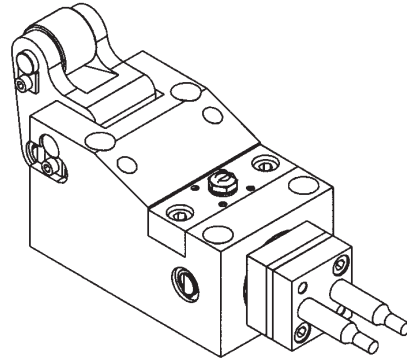
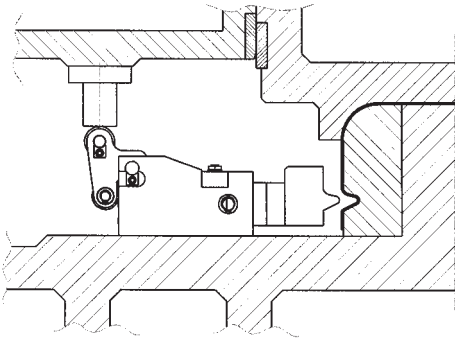



MDL GROUP



FRANCE

MDL
9 rue de l'Oberwald
F-68360 SOULTZ
✉ BP 126 - 68503 GUEBWILLER CEDEX
Tél. : +33 (0)3 89 74 24 24
Fax : +33 (0)3 89 76 49 99
E-Mail : mdl@mdl-rodix.com

GERMANY

Sitz :
Rodix GmbH
Heinrich-Krumm-Str.17
D-63073 OFFENBACH
Verkauf u.Beratung :
MDL RODIX GmbH
9 rue de l'Oberwald
F-68360 SOULTZ
Tel. : +49 (0)761 503127 11
Fax : +49 (0)761 503127 68
E-Mail : mdl-verkauf@mdl-rodix.com

BRAZIL

MDL
Av. Prink, No. 151
CEP 18120-000 MAIRINQUE, SP
Tél. : +55 11 2107 0400
Fax : +55 11 2107 0405
E-Mail : vendasp@mdl-danly.com.br

MEXICO

MDL DE MEXICO SA DE CV
Conjunto Victoria II
Acceso III No 52 Bodega 19
Zona Industrial Benito Juarez
CP 76120 QUERETARO
Tél. : +52 442 210 0020
Fax : +52 442 210 0012
E-Mail : ventas@mdlmexico.com.mx

U.S.A.

Mold & Die Components Inc.
4520 Progress Dr.
Columbus, IN 47201
Tél. : (812) 373-0021
Fax : (812) 373-0042
E-Mail : sales@mdlusa.com